

This document describes the procedure of changing the frequency on a Raven Starlink 310.

Please make sure your antenna is in clear view of the sky.

The following diagram illustrates the Configuration Menu for the Invicta 310. The highlighted boxes indicate the route to be navigated to change the frequency to the new OmniSTAR service.

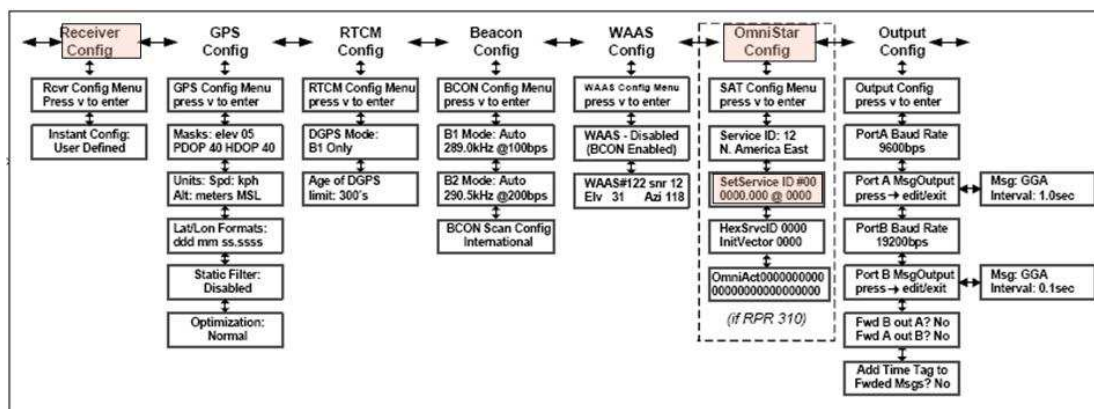

1. Using the **UP** [↑] and **DOWN** [↓] buttons navigate to the OmniSTAR “Config” menu.
2. Use the **DOWN** [↓] button to go to the “Set Service” screen, similar to the screen shown below.

SetService ID #11
 0000.000 @ 0000

3. Press the **ENTER** button to change the frequency and symbol rate. The leftmost digit of the satellite frequency will begin to blink. The frequency should be 1535.185. The symbol rate is 2438. Use the **UP** [↑] and **DOWN** [↓] buttons to change the digits. Use the **RIGHT** [→] button to move to the next digits. When both the frequency and symbol rates have been set correctly, save the changes by pressing the **ENTER** button.
4. Press the **UP** [↑] and **DOWN** [↓] buttons together, to return to the home menu. Then navigate to the OmniSTAR Display, and confirm that you have satellite lock indicated by “SAT Omni* Lock”.

When the frequency is correct, please call OmniSTAR to activate your receive to the new frequency while the unit is powered on and has a clear view of the sky. Please note your signal will not work until you call OmniSTAR to activate.

Please contact OmniSTAR on 1300 794 498 between business hours.